



anovafurnishings.com  
888.535.5005 tel

# ASSEMBLY INSTRUCTIONS

L1440A 4 ft Latitude Bench

L1441A 6 ft Latitude Bench

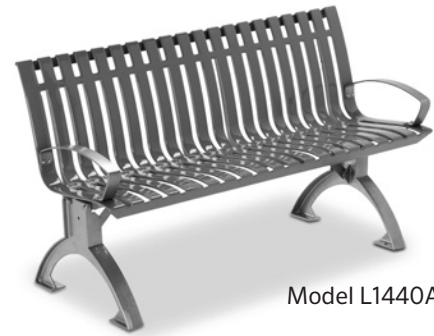

Model L1440A shown.

## TOOLS NEEDED:

- 9/16" Open-end or Box-end Wrench
- 1/2" Open-end or Box-end Wrench
- 5/8" Open-end or Box-end Wrench
- Ratchet with 1/2" Socket
- Ratchet with 9/16" Socket
- Ratchet with 5/8" Socket
- 3/16" Allen Wrench
- Level

## BENCH COMPONENTS:

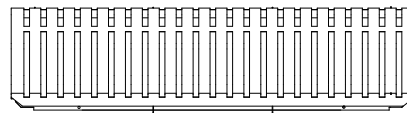

1 x Bench Seat

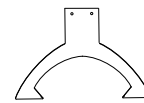

2 x Bench Legs



2 x Cross Braces



2 x Arm Rests

## ASSEMBLY HARDWARE:

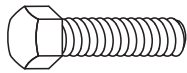

4 x  
5/16" X 1.25"  
Hex Head Bolt



8 x  
5/16"  
Washer



4 x  
5/16"  
Flanged Hex Nut

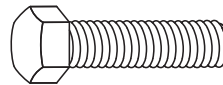

4 x  
3/8" X 1.5"  
Hex Head Bolt



8 x  
3/8"  
Washer

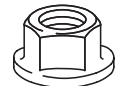

4 x  
3/8"  
Flanged Hex Nut

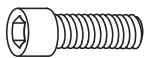

8 x  
5/16" X 1.0"  
Socket Head Bolt



16 x  
5/16"  
Washer



8 x  
5/16"  
Breakaway Nut

## ASSEMBLY:

The assembly is a two-person operation.

1. Inspect the shipping container contents for damage and to determine that all components and hardware are present.
2. Place the Bench Seat on the shipping packaging or other soft surface to avoid scratching the product.

Note: Before assembling the Nuts to the Bolts, it is recommended that a light oil or petroleum jelly be applied to the screw threads

3. Align the mounting holes in one of the Bench Legs with the holes in the appropriate end of the Bench Seat support. Insert one of the provided 3/8" Bolts, with a Washer, through both parts, with the Bolt head on the outside surface of the Bench Seat support. Install a Washer and Nut on the inside end of the Bolt.

Leave the hardware finger tight so that adjustments can be made later to level the Bench Seat.

Install a Bolt with Washer through the other mounting hole in that Bench Leg and Bench Seat Support and add a Washer and Nut to the end of the Bolt. Again, leave the hardware finger tight.

4. Repeat this for the other Bench Leg. Leave the hardware finger tight so adjustments can be made to level the Bench Seat.

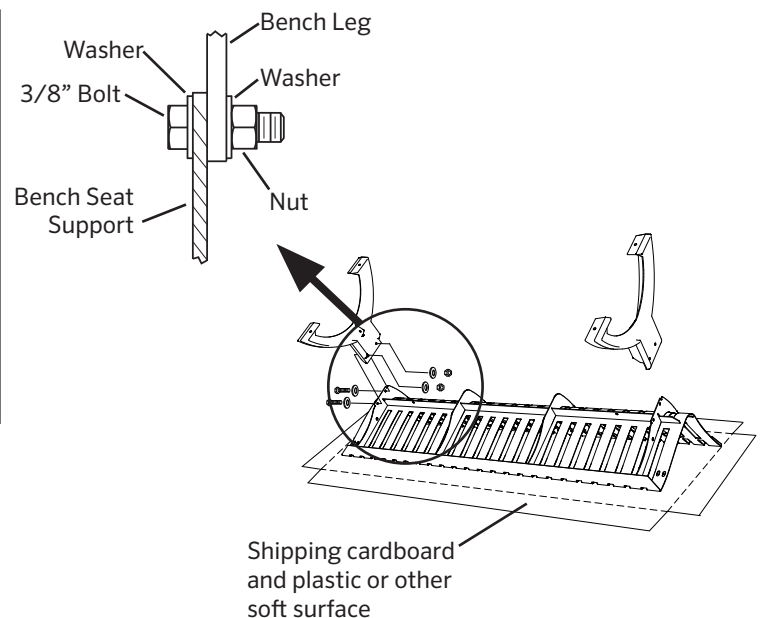

5. Attach the Cross Braces between the Bench Legs and the Bench Seat supports using the 5/16" Hex Head Bolts and Nuts with a Washer on each side as shown.

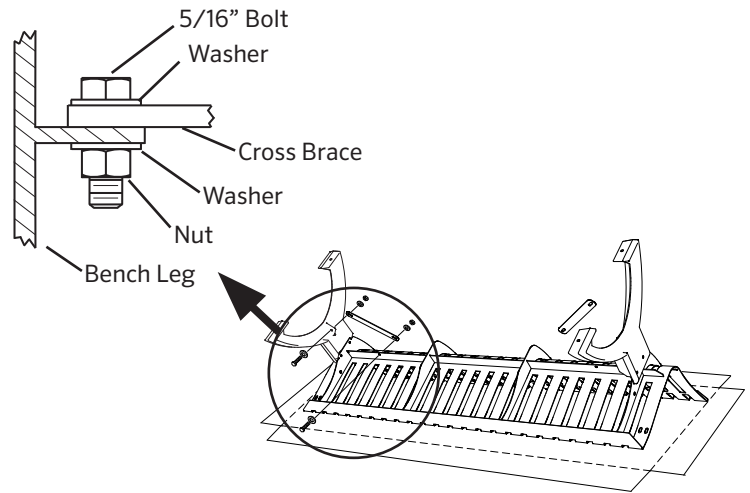

6. After the Leg Ends and Cross Braces have been attached to the Bench Seat, turn the bench upright and tighten all hardware while checking with the level.

7. Attach the Arm Rests using the 5/16" Socket Head Bolts with Washers and Breakaway Nuts as shown. Orient the Breakaway Nut so the cone shape is toward the Washer. Do not tighten the Nut; leave room to allow for adjustments. After all the fasteners have been installed in the Arm Rests, torque the Nuts until the hex head breaks off.

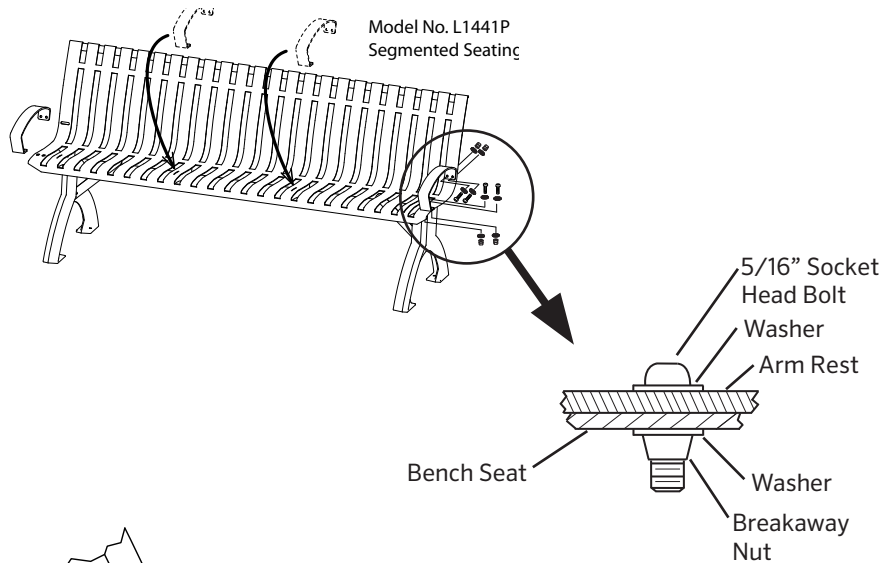

8. Retighten all hardware two weeks after initial assembly.

The feet of the Bench Legs feature a .40" diameter mounting hole for surface mount applications using customer supplied surface mount hardware.

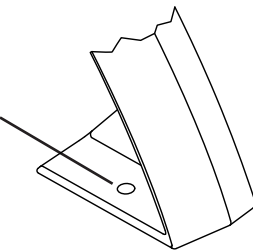

 <b>WARNING</b>	<ul style="list-style-type: none"> <li>Furniture must not be used other than for its intended purpose and should be inspected regularly for loose, missing, or broken hardware, and general instability.</li> <li>Furniture that is damaged or appears to be unstable must be removed from service and be repaired or replaced.</li> <li>Repairs must be made using only factory authorized parts and methods.</li> </ul>
--------------------	---

<b>CARE AND MAINTENANCE</b>	<ul style="list-style-type: none"> <li>Do not drag the assembled unit across any surface.</li> <li>This product requires only periodic cleaning with a sponge and a solution of mild detergent and water to remove surface dirt. Do not clean with a solvent or petroleum based products.</li> </ul>
-----------------------------	--



211 North Lindbergh Blvd.  
St. Louis, MO 63141

tel: 888.535.5005  
web: [anovafurnishings.com](http://anovafurnishings.com)