



anovafurnishings.com  
888.535.5005 tel

# ASSEMBLY INSTRUCTIONS

## Contour Benches, Inground Mount

**D1028** – Ultra 4’ Contour Bench, Perforated Steel

**D1029** – Ultra 6’ Contour Bench, Perforated Steel

**D6009** – Rally 4’ Contour Bench, Perforated Steel

**D6008** – Rally 6’ Contour Bench, Perforated Steel

**D6008COM** – Rally 6’ Contour Commemorative Bench, Perforated Steel

**F1028** – Ultra 4’ Contour Bench, Expanded Steel

**F1029** – Ultra 6’ Contour Bench, Expanded Steel

**L1344** – Ultra 4’ Contour Bench, Slotted Steel

**L1416** – Ultra 6’ Contour Bench, Slotted Steel

**C1416** – Ultra 6’ Custom Contour Bench, Slotted Steel

**C1416BB** – Ultra 6’ Contour Buddy Bench, Slotted Steel



D1029

### TOOLS NEEDED:

- 3/4" Open-end or Box-end Wrench
- Ratchet with 3/4" Socket
- Level

### ASSEMBLY HARDWARE:



4 x  
1/2-13 X 1.5"  
Hex Head Bolt



4 x  
1.375" OD x .109 THK  
Washer



4 x  
Belleville Washer

### BENCH COMPONENTS:

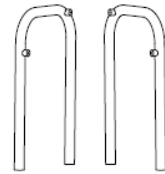

1x Right  
Bench Leg    1x Left  
Bench Leg

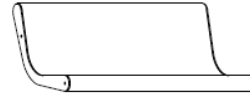

1x Bench Seat

### ASSEMBLY:

The assembly is a two-person operation.

1. Inspect the shipping container contents for damage and to determine that all components and hardware are present.

2. Place the Bench Seat on the shipping packaging or other soft surface to avoid scratching the product.

Note: When viewing the Bench Seat from the edge, the mounting hole nearest the end of the span indicates the seat portion of the and the mounting hole toward the middle of the span indicates the back rest portion.

3. Position one of the Bench Legs near the appropriate end of the Bench Seat. Align the mounting holes in the Bench Leg mounting bosses with the mounting holes in the appropriate end of the Bench Seat.

Note: Before assembling the Bolts, it is recommended that a light oil or petroleum jelly be applied to the threads.

Place a concave Belleville Washer on one of the bolts. Make sure the concave face of the Belleville Washer is facing away from the Bolt head. Then put on one of the Flat Washers. Install the Bolt through the Bench Seat into the threaded hole in the Bench Leg. Tighten the Bolt finger tight so that adjustments can be made.

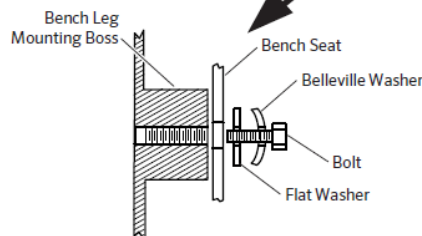
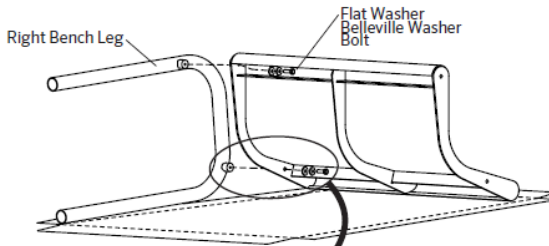
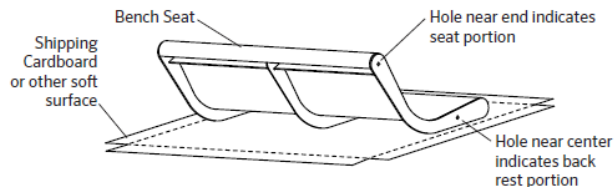

4. Install a Bolt and pair of Washers through the other set of mounting holes in that end of the Bench Seat and Bench Leg. Again, leave the hardware finger tight.
5. Attach the other Bench Leg to the other end of the Bench Seat in the same manner. Leave the hardware finger tight so adjustments can be made to level the Bench Seat.
6. After both Bench Legs are attached to the Bench Seat, turn the Bench right side up and tighten the Bolts while checking with a Level.

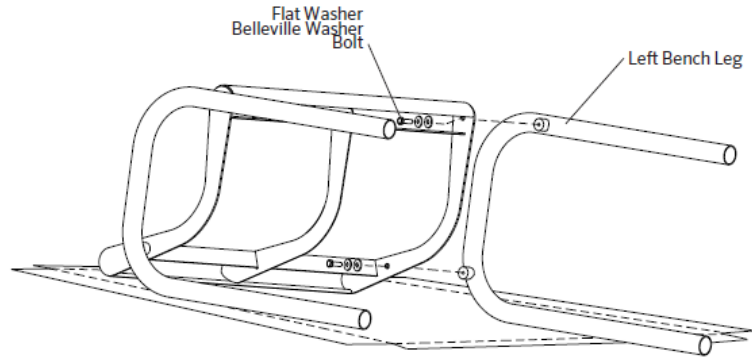

7. Determine the location for bench, locate underground utilities and avoid them while digging holes for concrete bases.
8. The walls of the concrete base should be vertical and smooth to minimize the effects of frost upheaval. This can be achieved with the use of concrete forms, such as Sonotube. Consider extending the concrete base below the frost line to eliminate the possibility of frost upheaval. Consult a professional for loose or unusual soil conditions.
9. Create a temporary structure that will be used to support the bench, at the desired height and level, while the concrete is curing.
10. Fill forms with concrete and insert supports, centered in concrete, until bench is supported by the temporary structure. Allow supports to fill with concrete. Crown the concrete cap to optimize drainage.
11. After concrete has cured remove temporary structure.
12. Retighten all hardware two weeks after initial assembly.

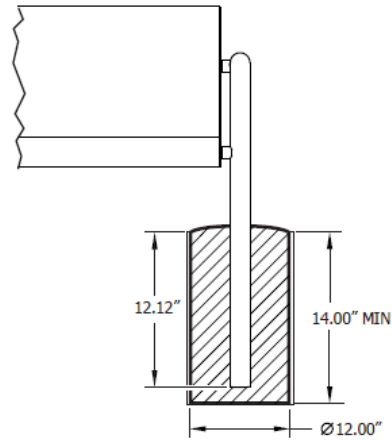

|   |   |
|---|---|
| <br><b>WARNING</b> | <ul style="list-style-type: none"> <li>• Furniture must not be used other than for its intended purpose and should be inspected regularly for loose, missing, or broken hardware, and general instability.</li> <li>• Furniture that is damaged or appears to be unstable must be removed from service and be repaired or replaced.</li> <li>• Repairs must be made using only factory authorized parts and methods.</li> </ul> |
| <b>CARE AND MAINTENANCE</b>   | <ul style="list-style-type: none"> <li>• Do not drag the assembled unit across any surface.</li> <li>• This product requires only periodic cleaning with a sponge and a solution of mild detergent and water to remove surface dirt. Do not clean with a solvent or petroleum based products.</li> </ul>  |