



211 North Lindbergh Blvd.
 St. Louis, MO 63141
 888.535.5005 tel
 314.754.0835 fax
 specify@anovafurnishings.com
anovafurnishings.com



D1021M
ULTRA RECEPTACLE
 32-gallon plastisol coated,
 perforated steel receptacle with
 liner and spun steel top

Material

The 32-gallon receptacle body is made of 12-gauge perforated steel with a .56" diameter uniform hole pattern. The receptacle is protected by Fusion Advantage™, a plastisol coating with an average .125" thickness and a high-gloss powder coat.

The contour top is made of 18-gauge galvanized steel protected by a fade resistant powder coat finish featuring a state of the art primer proven to prevent rusting. The top features a 10" diameter center opening for easy trash disposal and includes a 14" security strap.

The reusable 32-gallon plastic liner is made of black high-density polyethylene.

Finish

Fusion Advantage is a heat fused plastisol coating that creates an impervious rustproof barrier and resists UV deterioration, mildew, staining and fading.

The finish has been tested to the requirements of ASTM E1354 and is determined to be in compliance with California Uniform Fire Code 1103.2.1.4.2.

A state of the art primer and fade resistant powder coat is applied to the steel top, providing extreme rust fighting protection and durability. Treated components exceed the industry standard by 34% in testing by independent sources.

Color

See website or sales representative for color choices.

Assembly

Attachment of the top to the receptacle body requires minor assembly. Mounting options require some assembly also, if purchased.

Maintenance

The product is virtually maintenance-free and requires only periodic cleaning with a sponge and a solution of mild detergent and water to remove surface dirt. Do not clean with solvent or petroleum based products.

Warranty

20-year limited structural warranty with 7-year finish warranty from the date of purchase. See full details on multi-year warranties for components at www.anovafurnishings.com/warranty.aspx.

Replacement Parts

Black Plastic Liner **F1017**
 Universal Contour Top **F3005**

Accessories

Traditional In ground Mount **F1094**
 Traditional Surface Mount **F1098**
 45° Roadside Surface Mount **F1406**
 45° Roadside In ground Mount **F1407**
 Corkscrew Anchor **A1020**

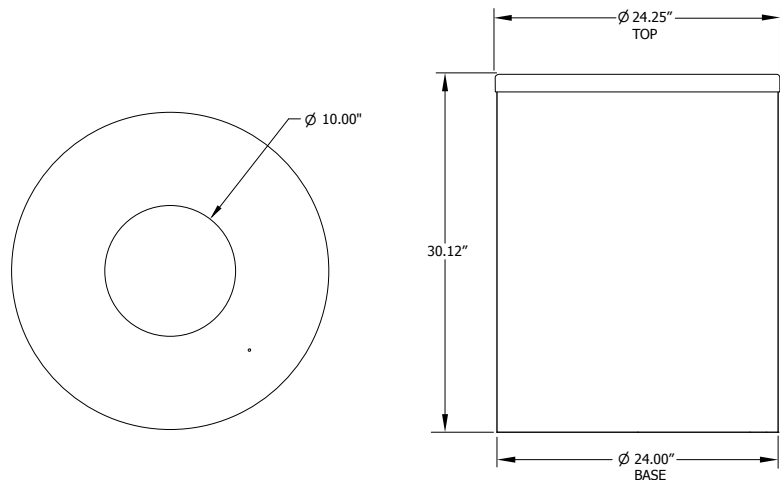

Shipping Information

Unit Wt.	Unit Shipping Wt. UPS (1- 2 Units)	Unit Shipping Wt. Truck (3+ Units)	Unit Ship Size w/Pallet	Max Units per Pallet	Pallet Wt. (48" x 32")	Total No. Pkgs	Shipping Class
78 lbs	110 lbs/unit	90 lbs/unit	32 cu. ft.	8	50 lbs	1	100